

Direct entry sealed termination unit for use with the Heat Trace range of heating cables

- Suitable for use in safe and hazardous areas.
- Eliminates the risk of damage to heating cables at termination points.
- IP54 rated.
- May be used for power connection, in-line and tee-splicing.

## FEATURES

The DESTU is a direct entry sealed termination unit for use with the majority of the Heat Trace range of self-regulating, and constant wattage heating cables.

Made from Glass Reinforced PPS, it has been designed specifically to reduce the risk of damage to heating cables at termination points. Thus avoiding the need to expose the heating cable as it emerges from the thermal insulation for connection into the junction box.

The DESTU may be used for power termination, in-line splice and tee splice terminations. When the RTD version of the unit is ordered, it is also suitable as a means of temperature sensing at various points along the length of heated pipework.

The DESTU is approved for use in non-hazardous and hazardous locations to EN EuroNorms.

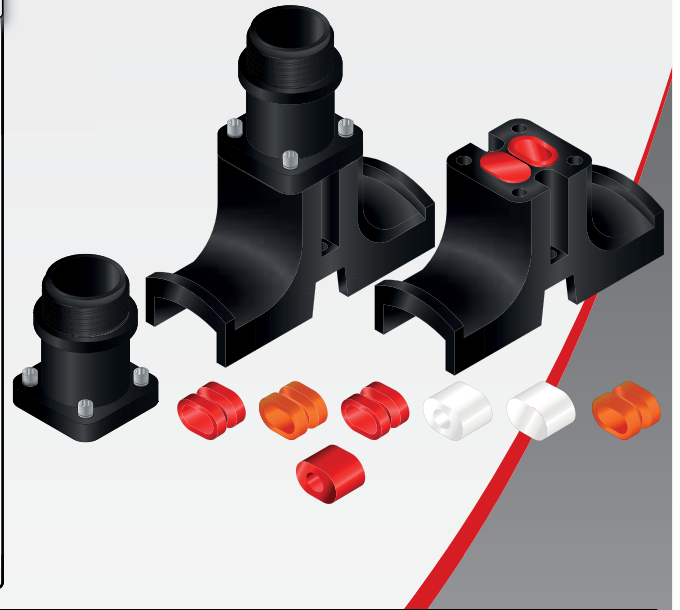

## OTHER EQUIPMENT NEEDED

### JUNCTION BOX

The suggested junction box for use with the DESTU system is the DJB9000. This style of junction box provides ample room inside for connecting the heating cables and earth wiring. The DJB9000 comes complete with the necessary terminal blocks and is drilled with a 33mm clearance entry to accept the DESTU. However, almost any style of junction box, provided it is drilled with a suitably sized DESTU entry, may be used.

### DESTU SEALS

Seals are required that have been specifically designed to seal correctly on the Heat Trace range of heating cables. The seals are positioned within the DESTU base and provide a means of passing the heating cable safely through the DESTU and into the chosen junction box. Refer to Heat Trace's comprehensive listing of the seal sizes needed for specific heating cables.

### END/POWER SEALS

Termination seals are required to provide a method of safe power and end termination of a heating cable. A tube of RTV silicone sealant is also necessary, (see ordering information). One tube for 6 seals is usually sufficient.

### PIPE FIXING STRAPS

Heat Trace suggest that the PFS range of pipe fixing straps is the most suitable method of holding the DESTU in position on the pipework. Refer to the table provided overleaf for details. Two PFS fixing straps are required per DESTU.

### OPTIONAL EQUIPMENT

A Pt100 RTD sensor may be purchased to enable the DESTU to be used as a pipe temperature sensing unit. See overleaf for details.

The DESTU may also be used in a tee-splice arrangement when additional components are ordered. See overleaf for further details. Should the surface pipe temperature of the pipe exceed 180°C a suitable thermal barrier is required.

# SPECIFICATION

**MAXIMUM EXPOSURE TEMPERATURE** 180°C (356°F)

<sup>1</sup>See note below about use of heat break

**MINIMUM OPERATING TEMPERATURE** -20°C (-4°F)

**DESTU DIMENSIONS (LxWxH)** 110 x 42 x 116mm

**IP RATING** IP54

**THERMAL BARRIER TEMPERATURE** Min. -45°C (-49°F)  
Max. 250°C (482°F)

**THERMAL BARRIER SIZE (LxWxH)** 130 x 62 x 45mm

**SENSOR CONSTRUCTION** Stainless steel tube with PTFE insulated wires and Pt100 RTD sensor.

## APPROVAL DETAILS

**Testing Authority** ATEX  **Certificate Number** SIRA 02ATEX3081U

## ORDERING INFORMATION

Cat Ref	Description
DESTU	DESTU 'top' and 'base' sections complete with locking ring, o-ring, blank seal, screw, shakeproof washer, instructions & caution label.
THERMAL BARRIER	Silicone rubber & mineral wool heat break
DRTD	RTD sensor and seal for DESTU
DESTU/T	Tee-splicing components including LEK/U lagging entry kit (separate product specific gland kit (PGSn or BGSn also required).
DSn	DESTU silicone rubber seal ('n' indicates nos 1 to 5)
PGSn	Plastic gland kit ('n' indicates nos 1, 3 or 5)
BGSn	Brass gland kit ('n' indicates nos 1 or 3)
BPSn	Silicone boot power seal ('n' indicates nos 4 to 5)
BESn	Silicone boot end seal ('n' indicates nos 4 to 5)
PFS025	Pipe fixing strap for <= 2" (50mm) pipework
PFS050	Pipe fixing strap for <= 5" (127mm) pipework
PFS100	Pipe fixing strap for <= 10" (254mm) pipework
PFS160	Pipe fixing strap for <= 18" (460mm) pipework
PFS200	Pipe fixing strap for <= 24" (635mm) pipework
RTV 0.5	Standard silicone sealant (max. 200°C)
RTV 1.5	High temperature silicone sealant (max. 250°C)

**Note:** 2 x PFS pipe fixing straps are required per DESTU unit

<sup>1</sup>Maximum pipe surface temperature when the thermal barrier is used is 250°C (482°F).  
Maximum pipe surface temperature without the thermal barrier is 180°C (356°F).  
We recommend use of a thermal barrier for DESTU and silicone end seals on pipes intended for operation in the range 180°C - 250°C. See RTV temperature range.

## DESTU - TOP & BASE SECTIONS

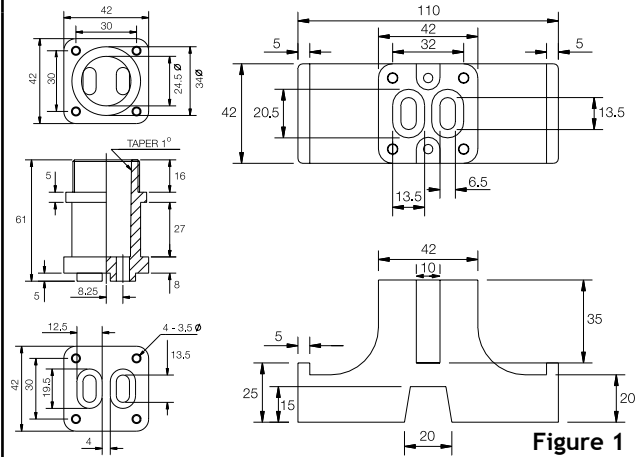

Figure 1

## DESTU - SENSOR AND SEAL DIMENSIONS

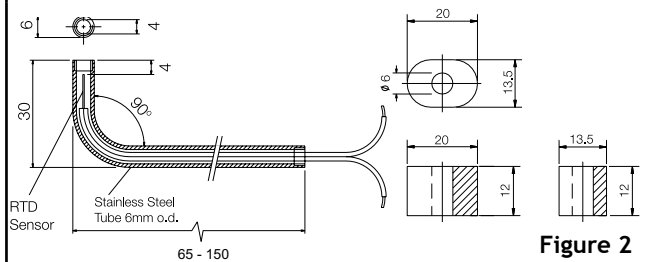

Figure 2

## TYPICAL DESTU USES

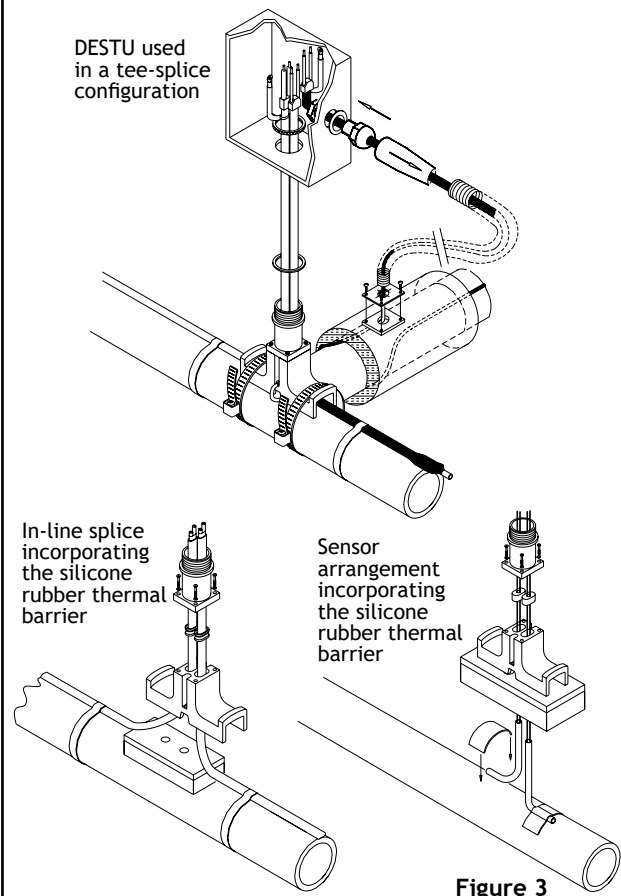

Figure 3



Heat Trace Ltd, Mere's Edge, Chester Road, Helsby, Frodsham, Cheshire, WA6 0DJ, England.  
Tel: +44 (0)1928 726451  
www.heat-trace.com Email: info@heat-trace.com

The information given herein, including drawings, illustrations and schematics are intended for illustration purposes only. Heat Trace Ltd makes no warranties as to its accuracy or completeness and disclaims any liability in connection with its use. Users of Heat Trace Ltd products should make their own evaluation to determine the suitability of each such product for specific applications. In no way will Heat Trace Ltd be liable for any damages arising out of the misuse, resale or use of the product.